

Technical Specifications (In-Cash Procurement)

Technical Specification Procedure for Irradiation testing on Fused Silica Diagnostic Windows

The purpose of this technical specification is the preparation of the irradiation testing specifications and procedures for Diagnostic Window Assemblies incorporating Fused Silica disks. The irradiation tests form part of the whole qualification program of the window assemblies.

Table of Contents

1	PURPOSE	2
2	SCOPE	2
3	DEFINITIONS	3
4	REFERENCES	3
5	ESTIMATED DURATION	3
6	WORK DESCRIPTION	4
6.1	Review of the irradiation tests performed in the past on Fused Silica materials	4
6.1.1	Deliverable	4
6.2	Technical specifications for irradiation testing	4
6.2.1	Deliverables	5
7	RESPONSIBILITIES	5
7.1	Contractor’s obligations	5
7.2	Obligations of the ITER Organization	6
8	LIST OF DELIVERABLES AND DUE DATES	6
9	ACCEPTANCE CRITERIA	6
10	SPECIFIC REQUIREMENTS AND CONDITIONS	7
11	WORK MONITORING / MEETING SCHEDULE	7
12	DELIVERY TIME BREAKDOWN	8
13	QUALITY ASSURANCE (QA) REQUIREMENTS	8
14	CAD DESIGN REQUIREMENTS (IF APPLICABLE)	8
15	SAFETY REQUIREMENTS	8

1 Purpose

The purpose of this technical specification is the preparation of the irradiation testing specifications and procedures for Diagnostic Window Assemblies incorporating Fused Silica disks. The irradiation tests form part of the whole qualification program of the window assemblies.

2 Scope

After a preliminary design phase addressing all different types of window assemblies expected to be used by the different diagnostic systems, the IO-CT strategy has changed. Most of the efforts on window assembly development now focus on one family of variations, which only incorporates Fused Silica disks. The new strategy is aimed at mitigating the project risks. The qualification of Fused Silica windows shall be first achieved and approved by the French Nuclear Authorities before starting the qualification of the other variations which make use of different disc materials.

Figure 1 : Overview of the Diagnostic window assembly

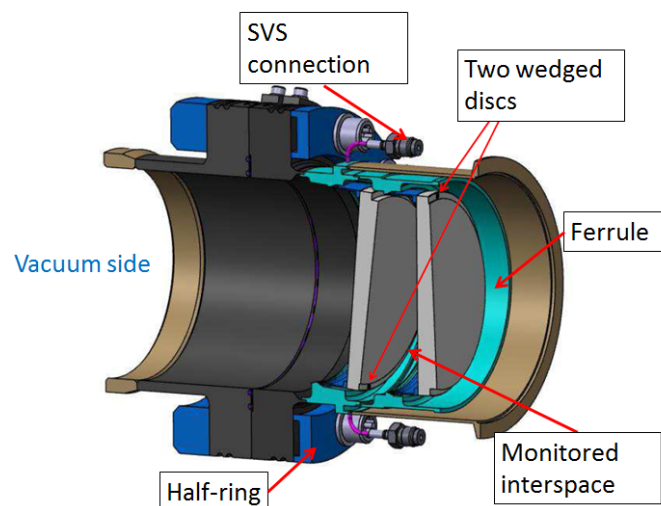

The works, which are specified in the present document, will be therefore carried out within the final design phase of the Diagnostic Window Assemblies provided with Fused Silica disks. The scope of works encompasses several activities listed below.

- Review of the irradiation tests performed in the past on Fused Silica materials.
- Preparation of the Technical Specifications and related procedures for irradiation testing (gamma and neutrons).
 - Irradiations tests on the transparent materials. Assessment of potential damages induced by gamma or neutrons irradiations.
 - Irradiations tests on diffusion bonded assemblies. Demonstrate that the bond will not be affected by gamma or neutrons irradiations : leak tightness and still strong from a mechanical point of view.
 - Irradiation tests as part of the ageing process, during the qualification of the window assemblies, if the previous tests demonstrate that the bond or the transparent material may be affected by irradiation exposure.

3 Definitions

For a complete list of ITER abbreviations see: [ITER Abbreviations \(ITER_D_2MU6W5\)](#).

4 References

Reference document	Comment
ITER_D_QCN8DN - Diagnostic Window Assemblies Load Specifications	PDR level
ITER_D_RCAJQF - Nuclear load specification on diagnostic window assemblies	PDR level
ITER_D_S3WECH - Qualification plan on window assemblies.	PDR level
ITER_D_TL59W9 - Properties of Fused Silica for ITER Diagnostic Window Assembly Applications	
ITER_D_S45G25 - Technical specifications for irradiation testing on window assemblies	PDR level

5 Estimated Duration

The overall duration of this contract is six months

6 Work description

6.1 Review of the irradiation tests performed in the past on Fused Silica materials

Many irradiation tests have been performed on Fused Silica, in particular on KU1 and KS4V in the past. A review of the existing results shall be first performed, to assess in which extent the available results match the environmental conditions expected on ITER machine. Provided that they are properly documented, existing results might allow the IO to avoid repeating some tests. The dose and fluxes expected on the ITER machine will be provided by the ITER organization as input.

As the diagnostic window assemblies are protection important components, the assessment shall take into account the completeness of the available test reports.

- Traceability of the samples (suppliers, material grade).
- Traceability of the irradiation conditions, (doses, fluxes, energy spectrum).
- Traceability of the testing conditions after irradiations, (calibration of the testing or measurement means).

Potential intellectual properties issues shall also be assessed, to make sure that detailed tests reports may be used by the ITER Organization to support the qualification file.

6.1.1 Deliverable

Assessment report of previous irradiation tests on Fused Silica material for windows.

6.2 Technical specifications for irradiation testing

This activity is aimed at finalizing the technical specifications for irradiation testing, which have been drafted for the PDR. Irradiation tests are indeed planned for several purposes:

- Measure key properties of Fused Silica after nuclear radiations. Key properties are those, which are essential regarding either the structural integrity or the signal transmission.

- Justify the integrity of the metallic bonding, which joins the fused silica disc on a metallic ferrule, after radiation exposure,
- Nuclear irradiation may form part of the ageing process of a window assembly, in case fused silica key properties or the metallic bonding are somehow affected after irradiation exposure.

The items, which shall now be consolidated are listed below.

[ITER_D_TL59W9 - Properties of Fused Silica for ITER Diagnostic Window Assembly Applications](#) now gathers data regarding changes in Fused Silica material properties due to irradiation exposure. The window failure modes listed in the current version of [ITER_D_S45G25 - Technical specifications for irradiation testing on window assemblies](#) shall be updated taking into account these data, and the fact that the technical specifications will now only cover fused silica windows.

Activation after radiation exposure shall be calculated for different types of samples:

- Fused Silica disc without mounting,
- Fused Silica disc bonded in a thin metallic ferrule,
- Single window sub-assembly or double window assembly.

The results of these calculations shall allow to define, which samples are still compatible with further tests in a non-nuclear testing facility. **Discussions with nuclear testing facilities are mandatory** to define, which tests are reasonably feasible after irradiation in a hot cell facility.

The size of the samples to be exposed shall also be defined, to conform with existing nuclear testing facilities. The definition of the samples shall be achieved in agreement with the ITER Organization, so that the expected failure modes can be highlighted after irradiations with tests achievable in a hot cell (shear tests, tensile tests, helium leak test,..).

Finally [ITER_D_S45G25 - Technical specifications for irradiation testing on window assemblies](#) shall be updated, while being consistent with the whole qualification program of the window assemblies. Detailed testing procedures shall come along with the technical specifications. The testing shall define:

- The chronology of the tests,
- The number of samples, taking into account contingencies for failed tests,
- The doses, fluxes, spectrum energy to simulate ITER end of life, and intermediate steps,
- The maximal temperature of the samples under irradiation,
- The key parameters to be monitored during the radiation exposure,
- The inspections before and after the irradiation tests,
- The tests and related procedures of the irradiated samples.

6.2.1 Deliverables

- Updated version of the Technical Specifications for Irradiation Testing on Window Assemblies.
- Detailed irradiation testing procedures.

- List of possible nuclear testing facilities able to perform these tests.

7 Responsibilities

7.1 Contractor's obligations

As itemized above, the Contractor shall provide specialist expertise required to achieve the activities listed in the present technical specifications. The work shall be performed according to deliverables defined in the present document.

The Contractor warrants, represents and undertakes that:

- The Contractor will provide the services promptly and with all due skill, care and diligence, in a good and workmanlike manner and otherwise in line with best practice within its industry.
- Contractor's personnel will possess the qualifications, professional competence and experience to carry out such services in accordance with best practice within the industry.
- The commitments on results taken when signing up to a specific task order shall be kept even when there are changes of the resources provided for it.

7.2 Obligations of the ITER Organization

The ITER Organization shall make available all data and information necessary to perform the activities specified in the present document.

- IO procedures required to achieve the activities according to ITER quality and safety rules,
- Nuclear environment expected for the Diagnostic Window Assemblies.

The ITER Organization shall give the possibility to the contractor to review documents on the ITER documents database (IDM).

8 List of deliverables and due dates

Delivery	Need date	Document package
1st sub-activity : Review of irradiation tests performed in the past on Fused Silica materials for optics		
Assessment report of previous irradiation tests on Fused Silica material for windows uploaded and approved in IDM.	T0 + 3 months	DP1-1
2nd sub-activity : Technical Specifications for Irradiation testing.		
Updated version of the Technical Specifications for Irradiation Testing on Window Assemblies, uploaded and approved in IDM.	T0 + 5 months	DP2-1
Detailed irradiation testing procedures, uploaded and approved in IDM.	T0 + 6 months	DP2-2
List of possible nuclear testing facilities able to perform the tests	T0 + 6 months	DP2-3

T0 is the date of the kick-off meeting.

9 Acceptance Criteria

Reports as deliverables shall be stored in the ITER Organization's document management system, IDM by the Contractor for acceptance. A named ITER Organization's Contract Technical Responsible Officer is the Approver of the delivered documents.

The Approver can name one or more Reviewers(s) in the area of the report's expertise.

The Reviewer(s) can ask modifications to the report in which case the Contractor must submit a new version.

The acceptance of the document by the Approver is the acceptance criterion.

10 Specific requirements and conditions

The Contractor's team shall cover all disciplines that may reasonably be required to carry out the Scope of Work.

It is noted that Contractor's personnel visiting the ITER site will be bound by the rules and regulations governing safety and security.

The Contractor shall have and maintain the necessary equipment and licenses to run the software tools required to carry out the tasks and produce the deliverables in accordance with the tools adopted by the IO. The Contractor shall ensure that experts are adequately supported and equipped. In particular it shall ensure that there is sufficient administrative, secretarial and interpreting provision to enable experts to concentrate on their primary responsibilities.

The official language of the ITER project is English. Therefore all input and output documentation relevant to this Contract shall be in English. The Contractor shall ensure that all the professionals in charge of the Contract have an adequate knowledge of English, to allow easy communication and adequate drafting of technical documentation. This requirement also applies to the Contractor's staff working at the ITER site or participating in meetings with the ITER Organization.

11 Work Monitoring / Meeting Schedule

The work will be started by a dedicated kick-off meeting and managed by means of Progress Meetings. It is expected that Progress Meetings will be held once a month at ITER site or by means of conference calls.

The main purpose of the Progress Meetings is to allow the ITER Organization/Diagnostics Division and the Contractor Technical Responsible Officers to:

- Allow early detection and correction of issues that may cause delays;
- Review the completed and planned activities and assess the progress made;
- Permit fast and consensual resolution of unexpected problems;
- Clarify doubts and prevent misinterpretations of the specifications.

In addition to the Progress Meetings, if necessary, the ITER Organization and/or the Contractor may request additional meetings to address specific issues to be resolved.

For all Progress Meetings, a document (the Progress Meeting minutes) describing tasks done, results obtained, blocking points and action items must be written by the Contractor during the meeting. Each report will be stored in the ITER IDM in order to ensure traceability of the work performed.

12 Delivery time breakdown

T0 is the date of the kick-off meeting. T0 is scheduled at the beginning of 2018 February.

Data package DP1 : T0 + 3 months

Data package DP2 : T0 + 6 months

13 Quality Assurance (QA) requirements

The organisation conducting these activities should have an ITER approved QA Program or an ISO 9001 accredited quality system.

The general requirements are detailed in [ITER Procurement Quality Requirements \(ITER_D_22MFG4\)](#).

Prior to commencement of the task, a Quality Plan must be submitted for IO approval giving evidence of the above and describing the organisation for this task; the skill of workers involved in the study; any anticipated sub-contractors; and giving details of who will be the independent checker of the activities (see [Procurement Requirements for Producing a Quality Plan \(ITER_D_22MFMW\)](#)).

Documentation developed as the result of this task shall be retained by the performer of the task or the DA organization for a minimum of 5 years and then may be discarded at the direction of the IO. The use of computer software to perform a safety basis task activity such as analysis and/or modelling, etc. shall be reviewed and approved by the IO prior to its use, in accordance with [Quality Assurance for ITER Safety Codes \(ITER_D_258LKL\)](#).

The use of computer software to perform a safety basis task activity such as analysis and/or modelling, etc shall be reviewed and approved by the IO prior to its use, it should fulfil IO document on Quality Assurance for ITER Safety Codes ([Quality Assurance for ITER Safety Codes 258LKL v2.2](#)).

The activities under these task order may be considered as substantiation elements for the Final Design Review. As such they may be considered as part of Protection Important Activities of the qualification. These activities must therefore be performed according to the French Order dated 7 February 2012 setting the rules relative to basic nuclear installations (see also §15).

14 CAD Design Requirements (if applicable)

Not applicable for the works specified in the present document.

15 Safety requirements

ITER is a Nuclear Facility identified in France by the number-*INB-174* (“Installation Nucléaire de Base”).

For Protection Important Components and in particular Safety Important Class components (SIC), the French Nuclear Regulation must be observed, in application of the Article 14 of the ITER Agreement.

As the window assemblies are Class 1 Safety Important Component :

- The Order 7th February 2012 applies to all the components important for the protection (PIC) and the activities important for the protection (PIA).
- The compliance with the INB-order must be demonstrated in the chain of external contractors.
- In application of article II.2.5.4 of the Order 7th February 2012, contracted activities for supervision purposes are also subject to a supervision done by the Nuclear Operator.

For the Protection Important Components, structures and systems of the nuclear facility, and Protection Important Activities the contractor shall ensure that a specific management system is implemented for his own activities and for the activities done by any Supplier and Subcontractor following the requirements of the Order 7th February 2012 [20].